

K	L
U	N





T O U C H T H E H E A V E N

S I N C E 1 9 8 0



# Created with the Diligence of Masters



Upholstery is a craft that doesn't demand only a man but his soul. Only a dedicated master is the one who delivers good products from his hands – whether it be an armchair, a sofa, a divan, or a couch set. We don't have a serial production, each piece is unique. Because there is a lot of handwork in each created piece, not even two couch sets or two armchairs are exactly the same. Not only that you get furniture made-to-measure, but we deliver furniture you have dreamed of.

We encourage sustainable use, quality, and eternal design. Couch sets are of such a quality that people don't change them according to the actual consumer cycle, and don't create unnecessary waste.

Seaway, Shippman 80, KLUN ambienti is a Slovenian family company with a long tradition in designing and production of padded furniture. We are a team of designers, engineers, masters upholsterers and seamstresses that connects culture of living with the modern design. We are offering diligent hands of our masters and installation of natural and high-quality materials.

Upholstery KLUN ambienti is tied to the tradition of craft and entrepreneurship. As the older master transfers his knowledge to his apprentices, so Karel Klun transferred his knowledge of company managing to his son Robert Klun.

Upholstery as well as entrepreneurship cannot be learned from books, the process of learning is personal.

Apart from knowledge, important values are transferred: trust, honesty, cooperation and giving a recognition to workers. We respect the knowledge of older masters and encourage younger generations to express fresh ideas.

Robert Klun, architect, designer, owner of Klun ambienti



# Architectural and Artistic Heritage

Although our home is Slovenia in the core of Europe, we reach across the border. You will find our products in the area stretching from the Balkans to the Scandinavian countries. We are encountering various cultural environments, such as for example the markets of the Persian Gulf. In Saudi Arabia we have furnished several hotels and resorts.

Everything that we are is also the result of our cultural environment. The architecture of Jože Plečnik, which accompanies us at every step, and numerous artists, such as the painter Ivana Kobilica, recall the archetypal artistic images.

Similarly, as Jože Plečnik at his time saw a deeper meaning in Central European connections, based on high-quality performance of outstanding individuals, we are also aware of our geographic position and cultural and artistic predispositions.

We are drawing inspiration from the culturally and aesthetically fertile environment, stretched between the Alps and the Adriatic Sea, between the relaxed Mediterranean attitude, and the precision of the North, between the history of Austria-Hungary and the orientation towards European future.





# SOFAS



KODDA



# K01



Its flexibility and a wide range of element, fabric colours of your choice and the durability of its construction and the fabrics will make Kodda the sofa of your carefree life.

Kodda K01 could be a perfect choice for most homes.

Design: Klun-ambienti, Robert Klun architect

Ergonomics and materials:

Construction: wooden with massive reinforcements, all materials are of Slovenian origin.

Seat: with spinning springs, coco, combination of high quality foamed material and wadding material.

Legs: round or square legs, wood or painted steel.

Upholstery: fabric or leather of top quality by client demand.

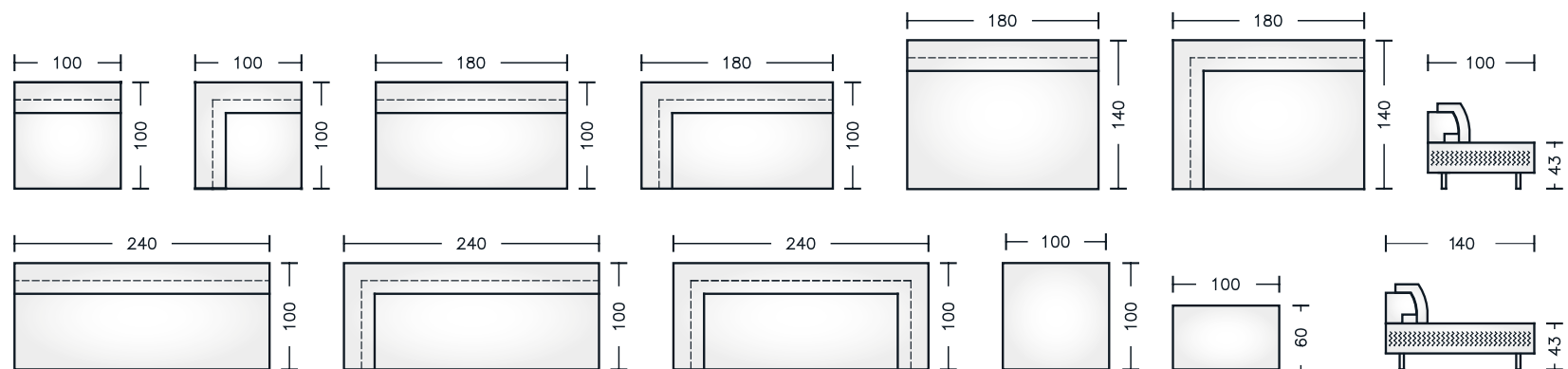

TOMAC



# K05



Elegant "minimal" sofa with aesthetic background, very suitable for free placement in the room.

Design: Klun-ambienti / Robert Klun architect.

Formation: all basic variations are designed with back and arm support.

Ergonomics and material:

Construction: made out of massive wooden panel plates.

Seat system: double spinning springs, coco and combination of high quality foamed and wadding material.

Legs: steel epoxy coated rounded legs.

Upholstery: bright selection of fabrics, micro textile and natural anillin leather.

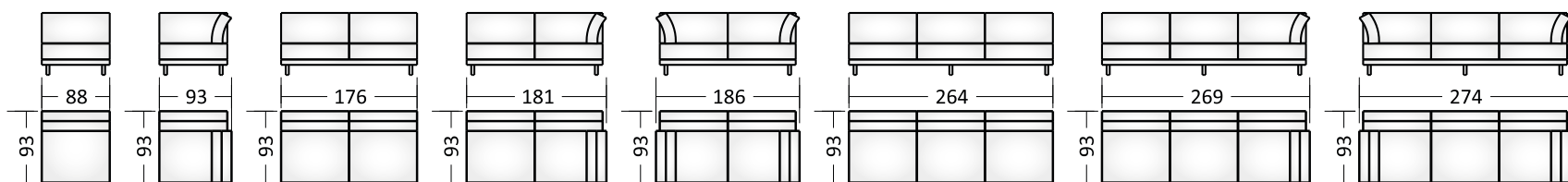

INCH



# K15



When elegance combines with comfort. A unique element in spaces where we want to combine the freedom of space and the coziness of the moment.

Oblikovanje: Klun-ambienti / Robert Klun architect

Formation: Basic elements which are designed to connect.

Ergonomics and materials:

Construction: made out of massive wooden panel plates.

Seat system: double spinning springs, coco and combination of high quality foamed and wadding material.

Legs: steel epoxy coated rounded legs.

Upholstery: selection of fabrics, micro textile and natural leather.

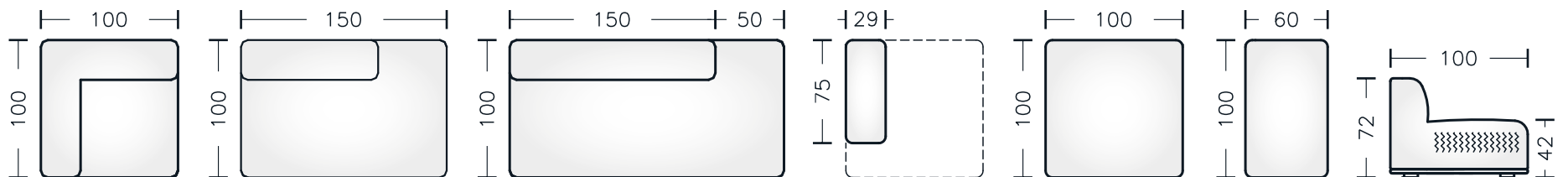

# ARRAGO





# K23



Multiplication in a circle, a semicircle. Soft lines and different segments that ennoble the spirit and ambience

Design:

Klun-ambienti, Gašper Demšar architect, Robert Klun architect.

Ergonomics and materials:

Construction: metal construction or chromium-plated, massive wooden construction.

Seat composition: swivel springs, coco-palm plate, combination of high quality foam.

Legs: inox or chromium-plated.

Upholstery: different fabrics, microfibers, leather or on client demand.

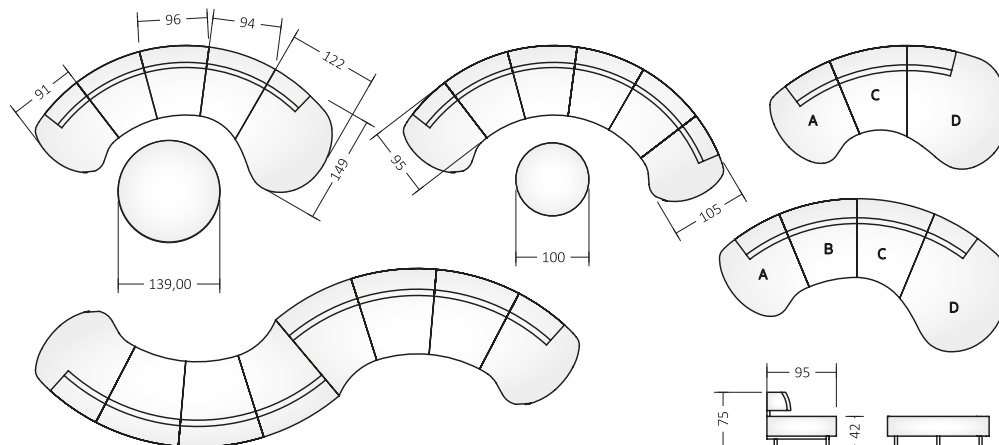

CLOUD



# K30



A seating set that offers the comfort of "sitting and enjoying the cloud". The Cloud element can be implemented as a single-seater, two-seater or three-seater. It is completely flexible when choosing arm-rests or back-rests.

Design: Klun-ambienti, Robert Klun architect.

Ergonomics and materials:

Construction: wooden construction, seat: massive panel plate with double springs, coco and combination of high quality foamed and wadding materials.

Legs: masive wooden legs.

Upholstery: fabric or leather of your choice. Specially tailored details on the upper corners of the seat and back segments.

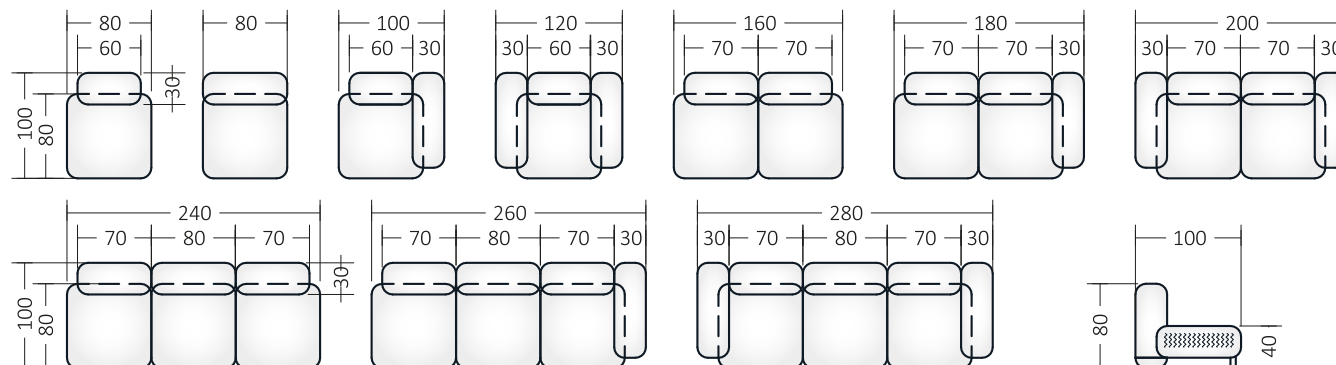

# CAMELEON



# K11



Lightweight and creative seating program that allows many color and layout combinations. It is more affordable and allows you to test the architect in yourself.

Golden Key Award at Furniture Fair in Belgrade 2012

Design: Klun-ambienti, Robert Klun architect.

Ergonomics and materials:

Ecological: solid wood, washable materials.

Construction: made out of massive wooden panel plates.

Seat: double spinning springs, coco and combination of high quality foamed and wadding material.

Legs: PVC rounded legs.

Upholstery: bright selection of fabrics, micro textile and natural anillin leather.

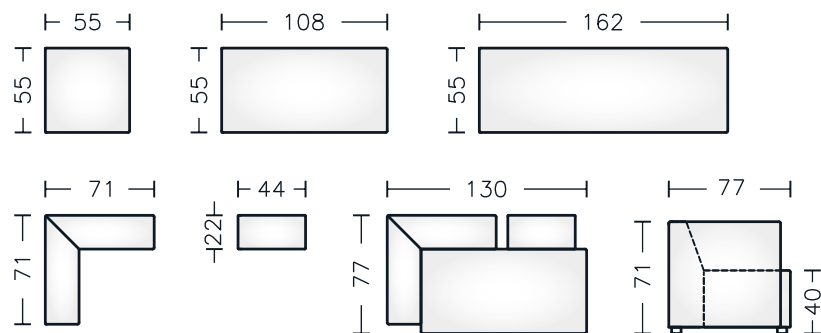

# PAPILLON



# K22



An elegant "minimal" sofa that offers many creative configuration options with just a few basic elements, very suitable for free placement in the room...

A special feature is the division into "bubbles" on one element, which are then modularly assembled into larger compositions.

Design: Klun-ambienti, Robert Klun architect.

Ergonomics and materials:

Construction: Wooden substructure in a combination of solid wood and panels. The upper panel is perforated for breathability.

Seat: A combination of high-quality HR down and wadding with the identity of "independent pillows"

Upholstery: Standard design in Nairobi fabric (CR\_A) or aquaclean fabric Duffy (CR\_B). Option in the execution of a wide selection of other fabrics, micro fabrics or leather of the client's choice by agreement.

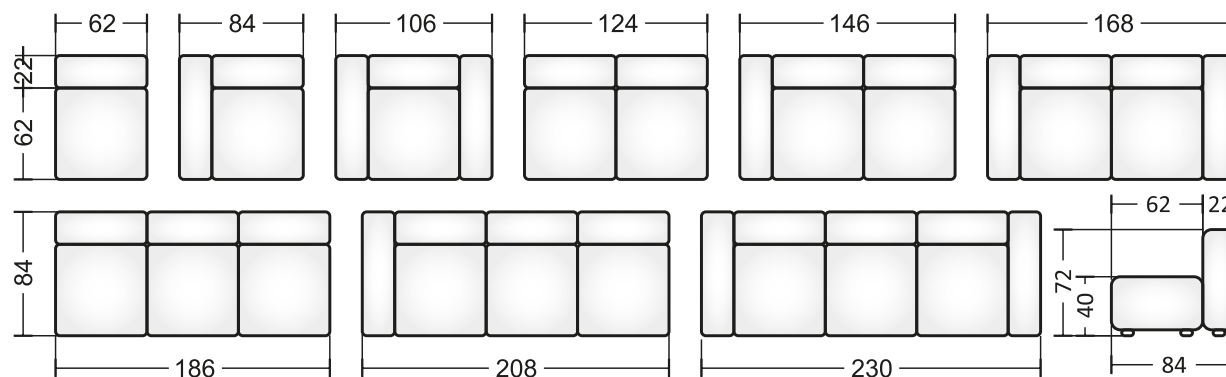

# BABALOO





# K90



The Babaloo designer piece enchants with its unique shape and versatility. By rotating the movable backrest, the two-seater changes into an extra bed. The organic shape of the sofa allows for both comfortable sitting and sleeping.

Design: Jurij Dobrila, Robert Klun architect

Ergonomics and materials:

Construction: massive wooden construction of the seat and back part.

Seat: combination of high quality foamed and wadding materials.

Base: wooden with PA legs.

Upholstery: different fabrics, natural or artificial leather.

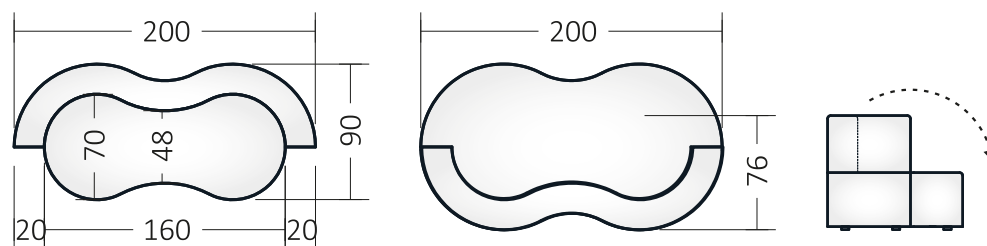



# OUTDOOR SOFAS



# RAIN SOFA



# C21



This elegant outdoor sofa will perfectly redesign your balcony, terrace, garden, wellnes or pool, in a new way.

Design: Klun-ambienti / Robert Klun architect

Ergonomics and materials:

Construction: powder coated aluminum construction.

Upholstery: nautical foams, UV resistant fabrics, detachable using velcro.

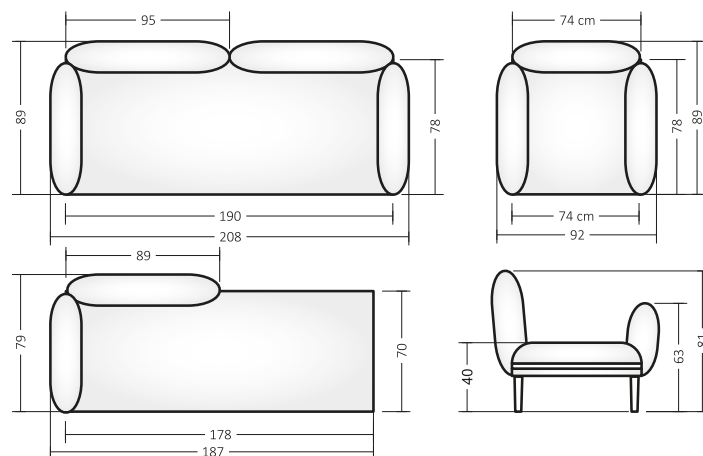

LINEAR



# K77



Lightweight lounge for home, garden, wellness, spa, lounge.  
Could be used in wet or dry space.

Design: Klun ambienti / Robert Klun architect

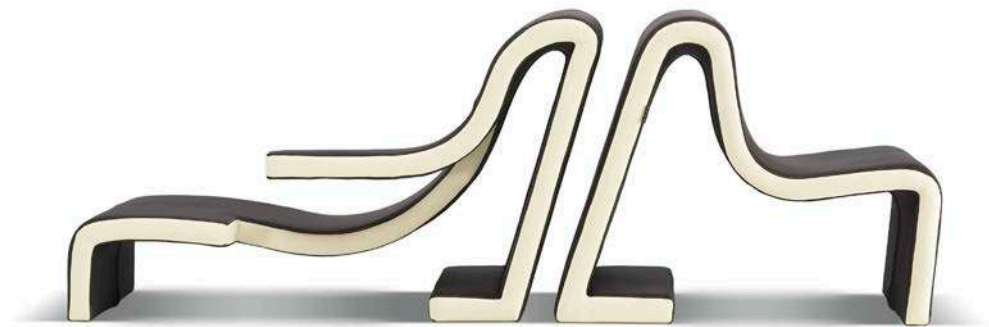

Ergonomics and materials:

Construction: epoxy coated skeleton.

Seat: quality special foamed material.

Upholstery: textile, leather, UV resistant fabric or other fabrics by client choice.

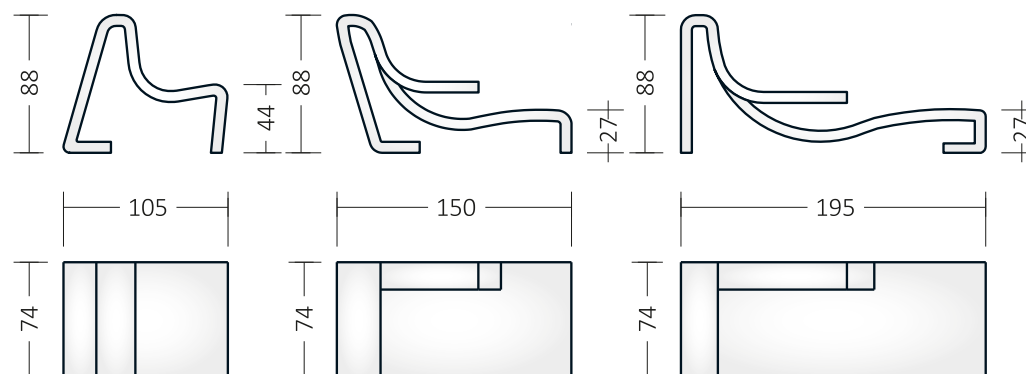





# LOUNGE CHAIRS



NOTTA

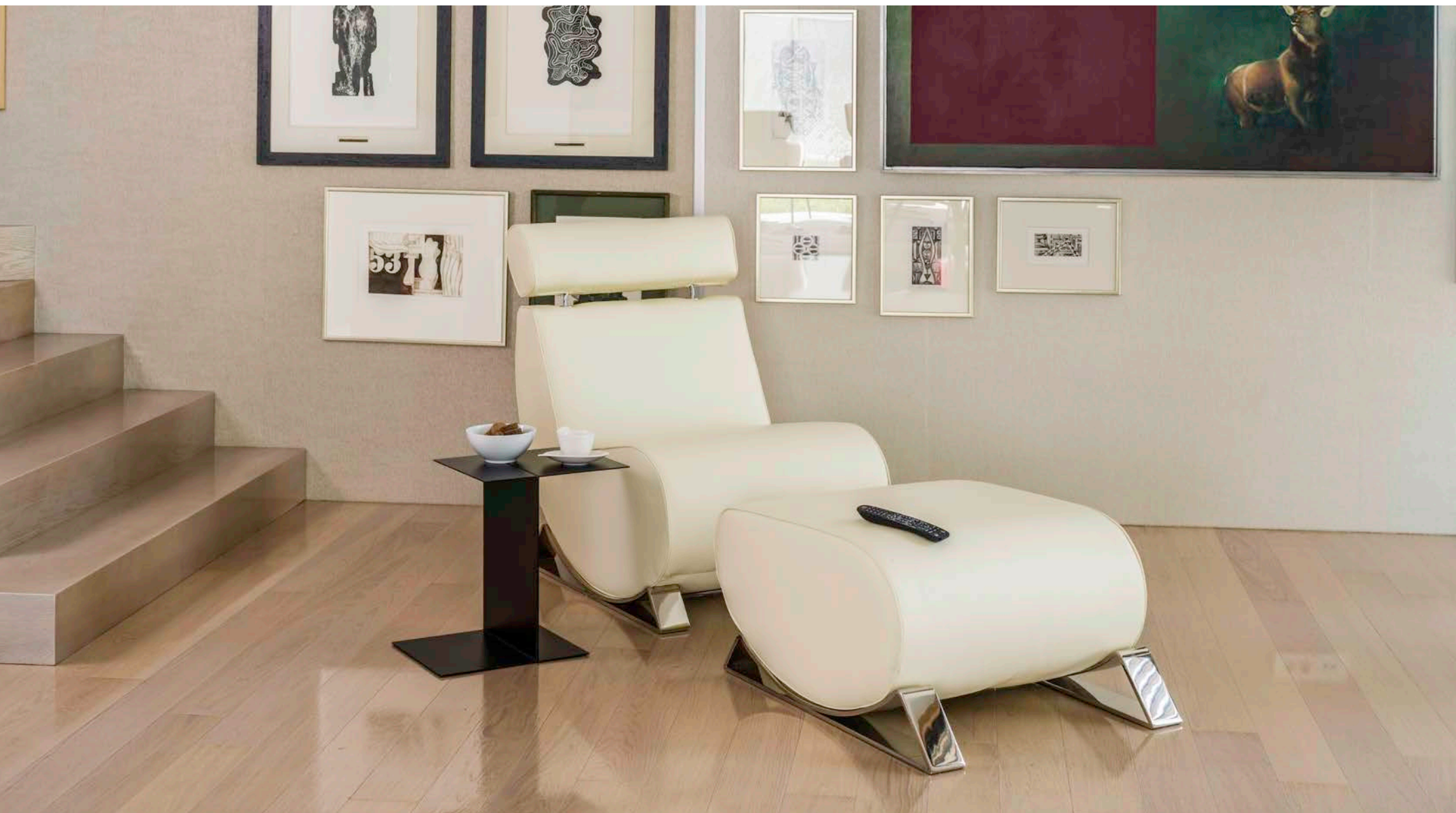

# K32



Comfortable recliner with attractive appearance that adapts to the user with rotation.

Design: Klun ambienti / Robert Klun architect

Ergonomics and materials:

Construction: solid wooden substructure.

Seat: "bonell" suspension, coconut fibre and quality foam.

Base: metal profile sleigh, chrome, stainless steel or painted according to customer's wishes.

Upholstery: a wide selection of microfabrics, leather or material by customers choice.

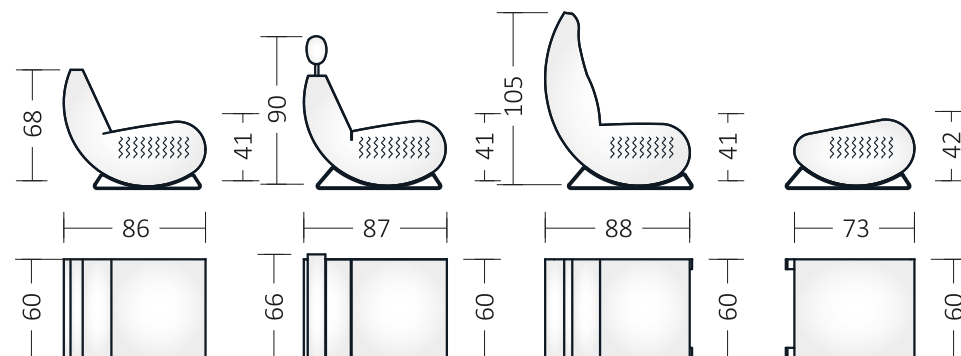

DAMMA



# K14



When the classic outgrows the modernism.  
"Canapé" or a lounge that provides an aesthetic aspect of the ambience in addition to comfort.  
Legs are designed like the beautiful heel of a woman's shoe.

Design:  
Klun ambienti, Špela Prezelj architect, Dunja Šutanovac architect

Ergonomics and materials:

Construction: massive wooden structure.

Seat: coil springs, coconut fibres and combination high quality foams.

Upholstery: different fabrics, natural leather.

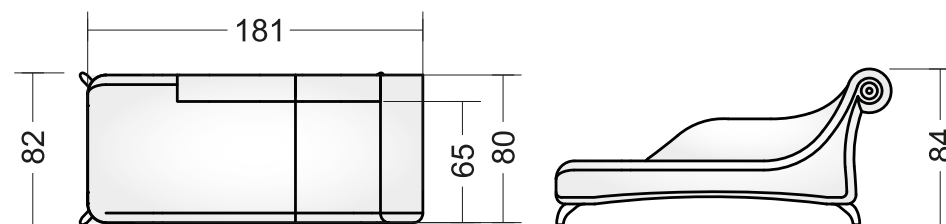

MONART



# K13



Sophisticated elegance of today for those who know how to indulge.  
Legs are designed like the beautiful heel of a woman's shoe.

Design:  
Klun-ambienti / Špela Prezelj architect, Dunja Sutanovac architect

Ergonomics and materials:

Construction: solid wooden construction, health-friendly materials of Slovenian origin.

Seat: classic seat with coil springs and natural coconut fibres with a combination of high quality foam.

Upholstery: fabrics by customers choice.

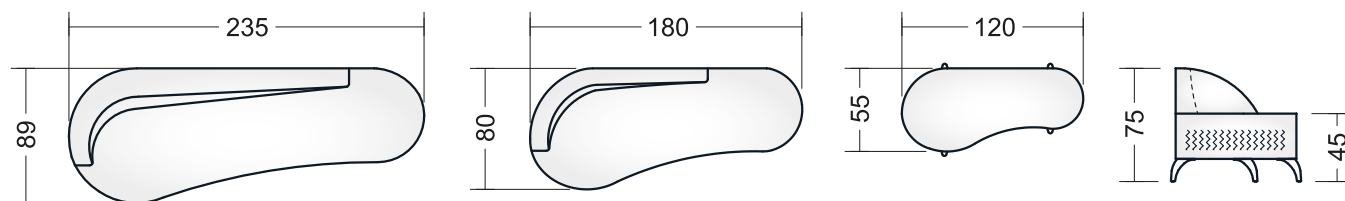

LINEAR





# K77



Lightweight lounge for home, garden, wellness, spa, lounge.  
Could be used in wet or dry space.

Design: Klun ambienti / Robert Klun architect

Ergonomics and materials:

Construction: epoxy coated skeleton.

Seat: quality special foamed material.

Upholstery: textile, leather, UV resistant fabric or other fabrics by client choice.

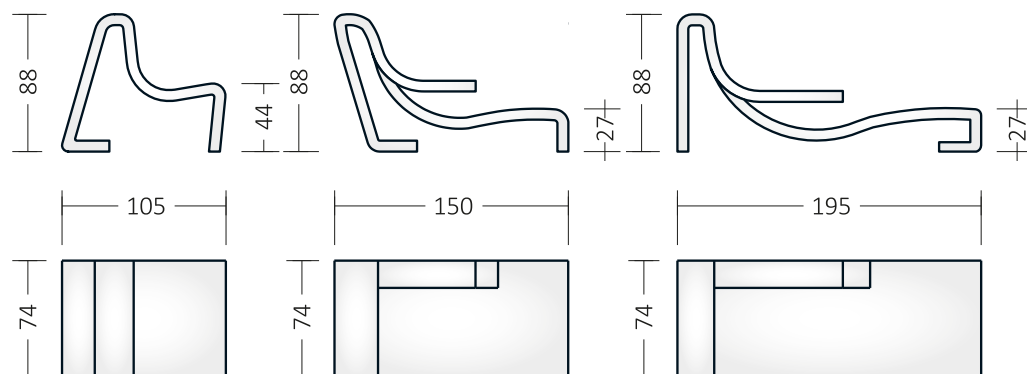

# BIG APPLE



# K88



## Big Apple:

The "Big Apple" could be placed everywhere in ambient. Placed in ambient with book shelves or audio elements, or could stand alone where remarkable ambient starts. You will find safety and shelter. No noise and in constant connection with environment itself.

Design: Klun ambienti / Robert Klun architect

## Ergonomics and materials:

Construction: Hand made element with metal construction and high quality foam.

Upholstery: artificial or natural leather in 4 colours.

## Optional:

Big apple can be equipped with speakers and bluetooth, holder with charger for smartohone, remote controlled from all devices.

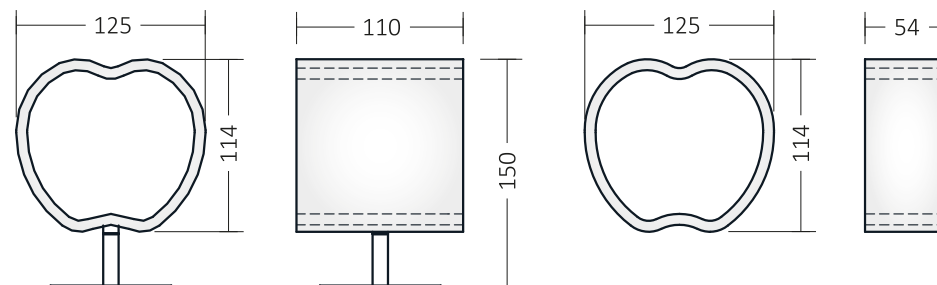

**BIG 0**



# K88



Innovative wall element with a diameter of 125 cm! Designed to enchant you.

The Big is intended for wall mounting.

Selection of at 100% Design 2008 award in London.

Design: Jurij Dobrila.

Ergonomics and materials:

Construction: metal construction, high quality foamed material.

Upholstery: artificial or natural leather by customers choice.

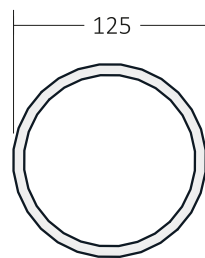

# SEAT 0



# K88



Innovative serial wall elements for multi-stage use... Serial elements that can be added and built as desired.

Wall furniture that creates timeless, sustainable and aesthetically accomplished spaces, which are going to inspire you and support you at what you do and what you are. Make the most of space in lounge bars, clubs, offices, waiting rooms, lobbies, and more.

Design: Jurij Dobrila.

Ergonomics and materials: metal construction, high quality foamed material, upholstery: artificial or natural leather by customers choice.

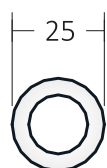

SILENT





# K92



Silent furniture has been developed for a simple reason - to bring back peace and privacy to open offices. Innovative design and sound-friendly construction materials achieve significant noise reduction. The interior is friendly, and the upholstery provides a general sense of comfort.

Design: Jurij Dobrila

Ergonomics and materials:

Construction: metal and wooden construction, high quality foamed material.

Upholstery: sound absorbing fabrics.

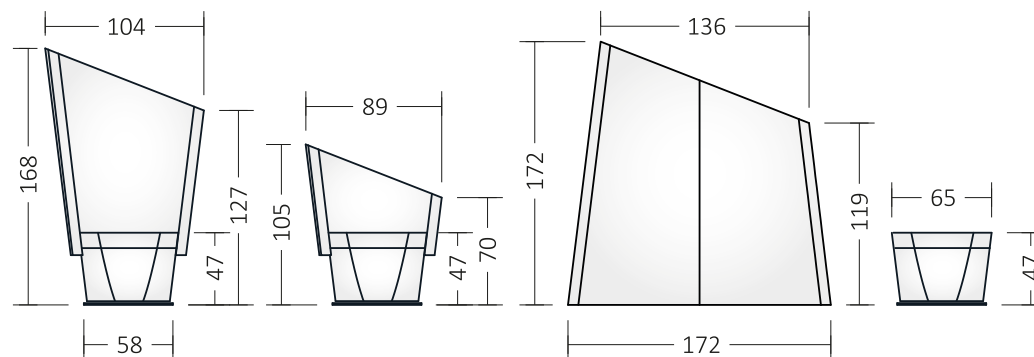

# C19 CHAIR.ITY

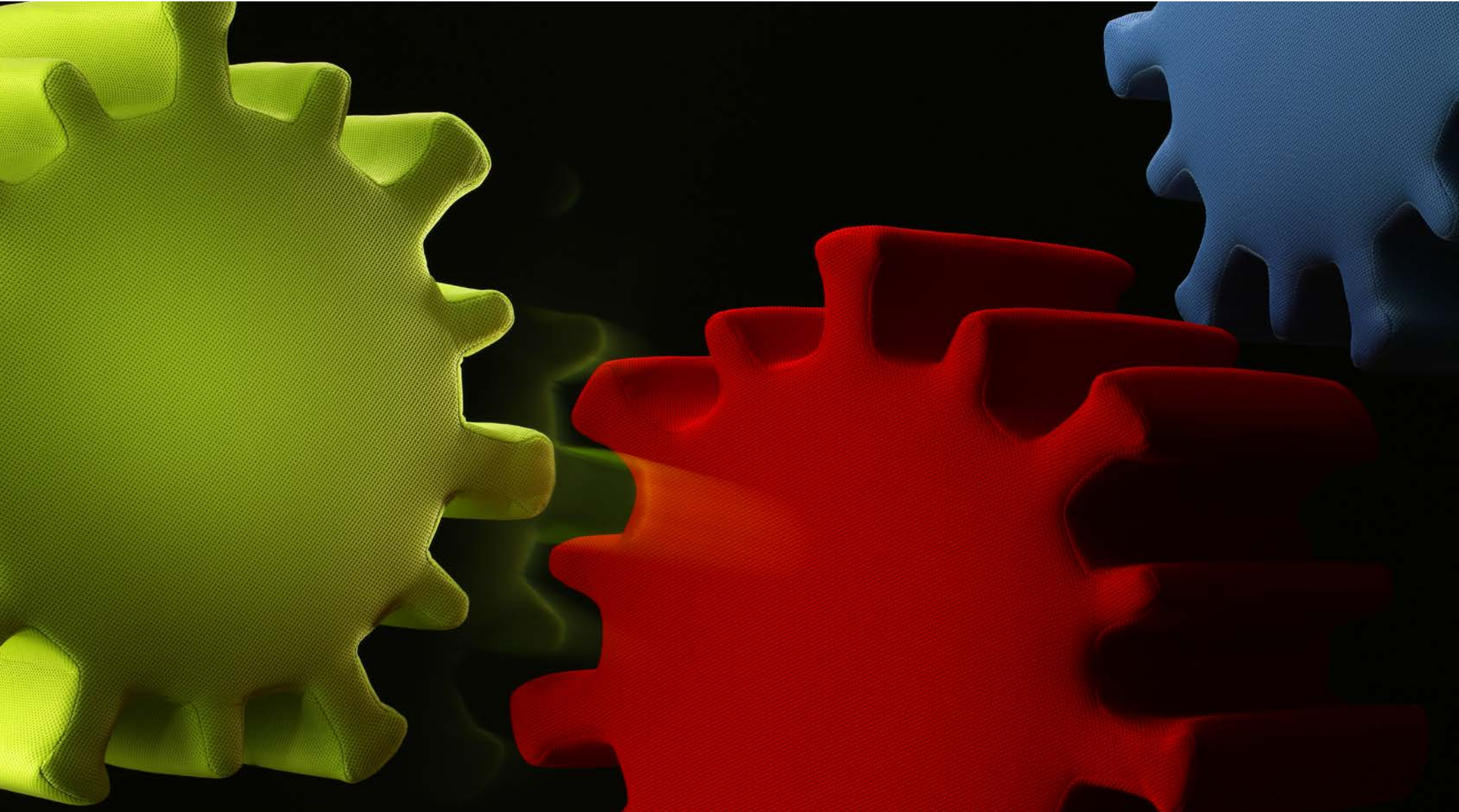

# C19



Difficult times are inspiring and encourage new solutions.

The C19 CHAIR.ity was designed as response to the pandemic of the new corona-virus time. The chair deals with it in an unique psychological way. While resting on it, you feel positive energy and inner strength over the disease.

The unification of more chairs gives new forms that symbolize interconnectedness of society.

It reminds us that man is a social being, and only the closeness of a fellow human being contributes to his personal development.

Ergonomics and materials:

Construction: solid wooden substructure.  
Upholstery: the best anti-allergic materials.

Design:  
Klun ambienti / Robert Klun architect

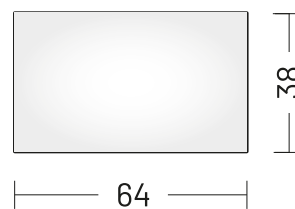
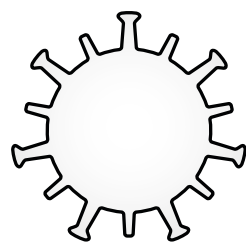



# REFFERENCES

DESIGN

DEVELOPMENT

MANUFACTURING

INSTALLATION



**MAGNET DESIGN**



# REFERENCES



## HOTELS

1. Mons Design Hotel, Ljubljana, Arch.: Podrecca, Dobrina
2. Four Points by Sheraton Hotel, Ljubljana
3. Canary Hills Compound, Kingdom of Saudi Arabia
4. Canary Hills Flats, Kingdom of Saudi Arabia

## OFFICES

5. Office Ars Incolendi, Ljubljana, Arch.: Gregorčič
6. Epilog Office, Ljubljana, Arch.: Pirš







# REFERENCES

## PUBLIC

7. Opera & Ballet House, Ljubljana, Arch.: Zupan, Kobe
8. Lobby Christall Tower, Ljubljana, Arch.: Smolej
9. Pilates Wellness Center, Ljubljana, Arch.: Krušec
10. Wine Shop Rozmarin, Maribor, arch.: Aksl
11. Restaurant Element, Ljubljana, Arch.: Aksl
12. Restaurant Alrashid, Kingdom of Saudi Arabia





# REFERENCES



## PUBLIC

- 13. Hotel Marriott, Riyadh, Kingdom of Saudi Arabia
- 14. Boutique Monarda, Ljubljana, Arch.: Prezelj, Šutanovas

## MEDICAL

- 15. Morela Optics, Ljubljana
- 16. Medical Private Cell

## CUSTOM

- 17. Chesterfield Bed and Armchair, Design: Klun

## NAUTIC

- 18. Seaway, Shippman 80, Design: Jakopin



